

# MARS-3250-12U3M/C

MARS USB3.0 Series 32.5MP CMOS USB3.0 Area Scan Camera



USB<sup>TM</sup>  
VISION

GEN<i>i>CAM

CE

FC



The MARS-3250-12U3M/C camera is a monochrome/color GigE Vision camera with the ON XGS32000 CMOS sensor. Thanks to locking screw connectors, the MARS cameras can secure the reliability of cameras deployed in harsh environments. The MARS-3250-12U3M/C camera has opto-isolated I/Os. The GPIOs give MARS-U3 cameras maximum flexibility to adapt to specific needs.

## Applications

Suitable for machine vision applications such as industrial inspection, medical, scientific research, education, security and so on.

## Features

- Trigger mode: Frame Start /Frame Burst Start
- Two exposure time modes: Standard exposure time mode / UltraShort exposure time mode
- Support Timed exposure mode and TriggerWidth exposure mode
- Support Gamma, Binning, Decimation, Digital Shift, Black Level, Flat Field Correction and Static Defect Correction
- Color models support Light source preset, Color Transformation Control and Saturation
- Monochrome models support Sharpness and Noise Reduction
- Programmable LUTs and storable user sets
- Support Timer and Counter
- Support Remove Parameter Limit to expand the range of exposure, gain, white balance, and so on
- 16KB data storage area for saving algorithm coefficients and parameter configuration

## Specifications

Model	MARS-3250-12U3C	MARS-3250-12U3M
Resolution	6576(H) × 4940(V)	
Sensor	ON XGS32000, Global shutter CMOS	
Sensor Format	APS-C	
Pixel Size	3.2μm × 3.2μm	
Frame Rate	12.1fps	
ADC	12bit	
Pixel Bit Depth	8bit, 12bit	
Mono/Color	Color	Mono
Pixel Formats	Bayer RG8 / Bayer RG12	Mono8 / Mono12
SNR	39.56dB	39.61dB
Exposure Time	Standard: 162μs ~ 1s(RemoveParameterLimit to expand the shutter time to 15s), Actual Steps: 1 row period; UltraShort: 92μs ~ 161μs, Steps: 1μs	
Gain	0dB ~ 24dB; Default: 0dB, Steps: 0.1dB	
Binning	1×1, 1×2, 1×4, 2×1, 2×2, 2×4, 4×1, 4×2, 4×4	
Decimation	Sensor: 1×1, 1×2, 2×1, 2×2	
Synchronization	Hardware trigger, software trigger	
Acquisition Mode	Single frame, Continuous, Software trigger, Hardware trigger	
Reverse X/Y	Reverse X/Y	
I/O Interface	1 input and 1 output with opto-isolated, 2 programmable GPIOs	
Data Interface	USB3.0	
Power Supply	12VDC-10% ~ 24VDC+10%	
Power Consumption	< 5.6W @ 24VDC	
Operating Temp.	0°C ~ +45°C	
Storage Temp.	-20°C ~ +70°C	
Operating Humidity	10% ~ 80%	
Lens Mount	M42 / F	
Dimensions	62(W) × 62(H) × 53.77(L) mm	
Weight	308g	
Software	3rd-party software such as HALCON, MERLIC and LabVIEW	
OS	32bit / 64bit Windows, Linux, Android, ARMv7, ARMv8	
Conformity	CE, RoHS, FCC, GenICam™, USB3 Vision®	

I/O Interface

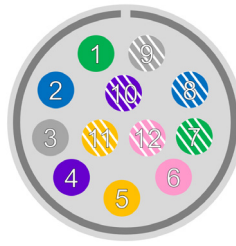

Pin	Definition	Core Color	Description
1	Line0+	Green	Opto-isolated input +
2	GND	Blue	PWR GND & GPIO GND
3	Line0-	Grey	Opto-isolated input -
4	POWER_IN	Purple	Camera external power, +12V DC(-10%)~+24V DC(+10%)
5	Line 2	Orange	GPIO input/output
6	Line3	Pink	GPIO input/output
7	Line1-	White Green	Opto-isolated output -
8	Line1+	White Blue	Opto-isolated output +
9	NC1	White Greg	Not connected, reserved
10	GND	White Purple	PWR GND & GPIO GND
11	NC2	White Orange	Not connected, reserved
12	NC3	White Pink	Not connected, reserved

Spectral Response

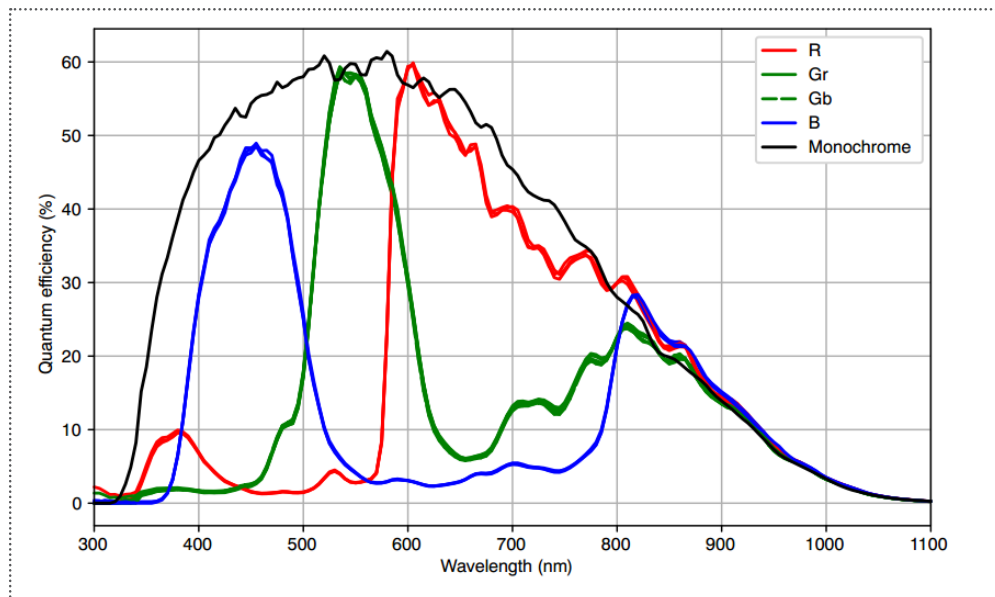

MARS-3250-12U3M/C

Technical Drawing

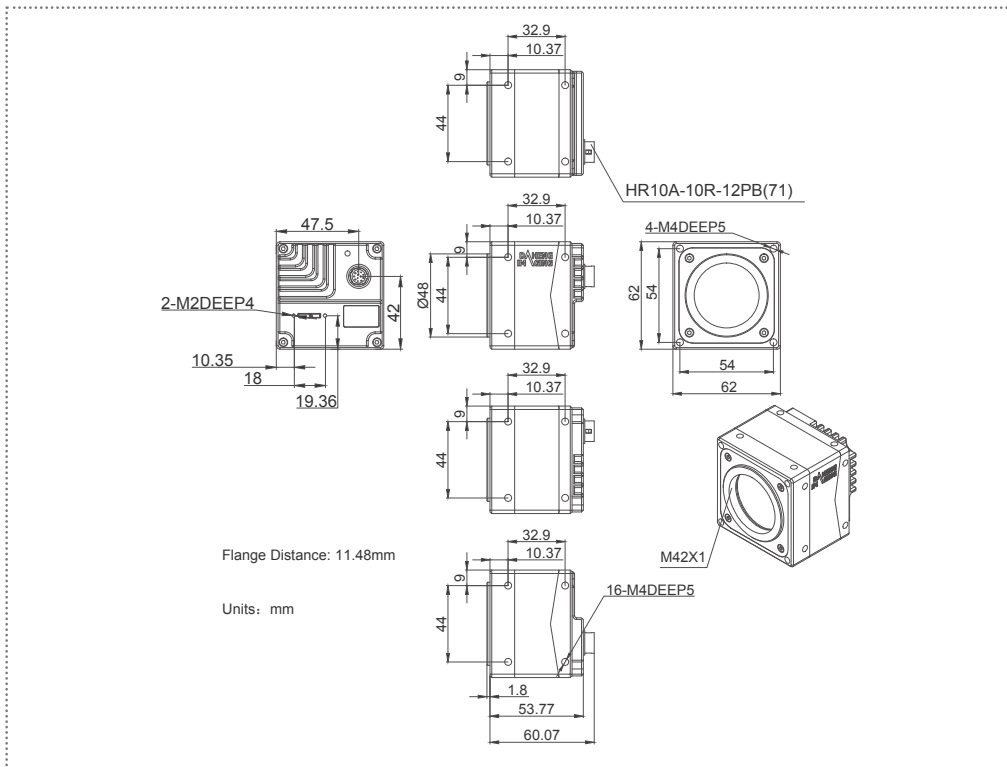

MARS-3250-12U3M/C M42 Mount

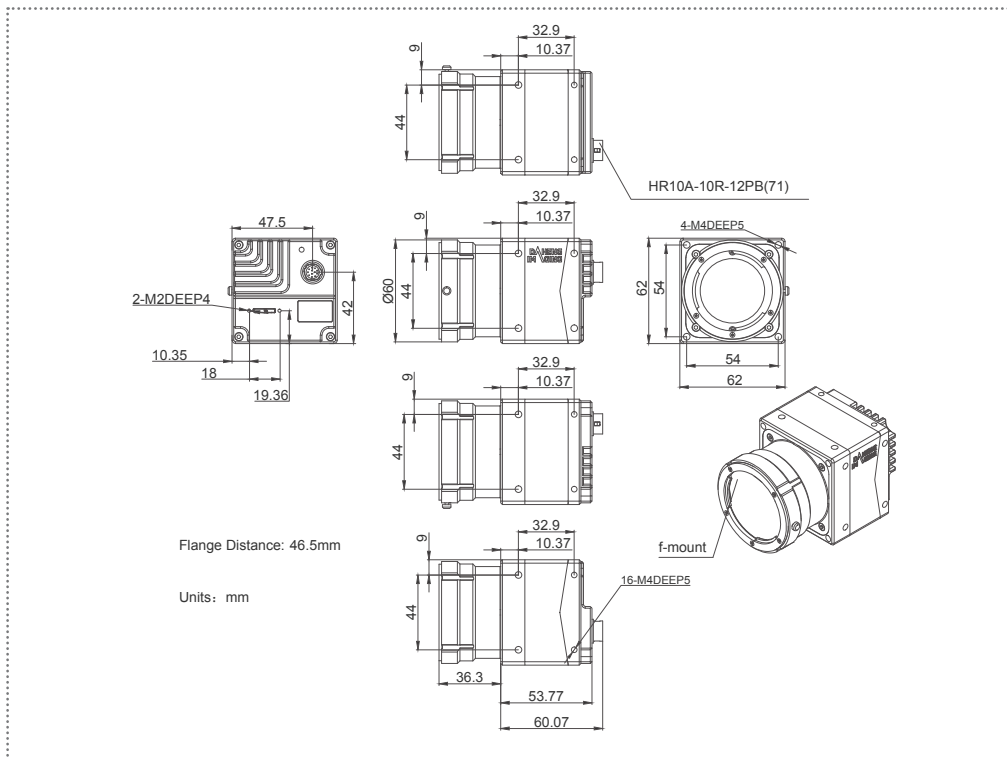

MARS-3250-12U3M/C F Mount

China Daheng Group, Inc. Beijing Image Vision Technology Branch

12F Daheng Science & Technology Tower, No.3 Suzhou Street, Haidian District, Beijing China, 100080

Tel: +86 10 82828878

E-mail: isales@daheng-imaging.com