

MARS-900-120GTM/C

9MP CMOS 10GigE Area Scan Camera



The MARS-900-120GTM/C is a monochrome/color GigE Vision camera with the Gpixel GMAX2509 CMOS sensor. The MARS-900-120GTM/C is capable of 10Gbit/s maximum transfer data rate, and has opto-isolated I/Os. Thanks to locking screw connectors, the MARS cameras can secure the reliability of cameras deployed in harsh environments. The MARS cameras are industrial digital cameras with high reliability and high performance ratio.

Applications

Suitable for 3C, lithium battery, photovoltaic, railway, AR and other industrial applications.

Spectral Response

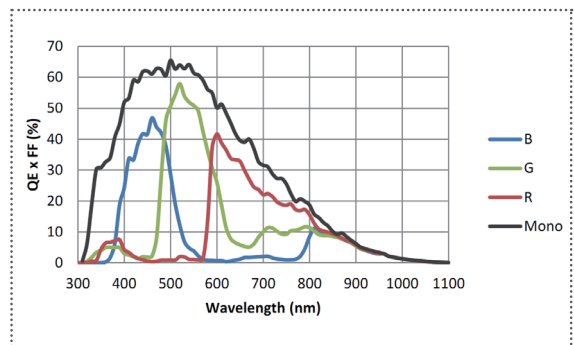

Features

- Time Stamp, Horizontal Binning, Decimation, Reverse X/Y
- The Sequencer Control supports multiple sets of parameters configuration
- Trigger mode: Frame Start /Frame Burst Start
- Gain, GainAuto, Gamma, Black Level, Digital Shift, Flat Field Correction
- Color models support Light Source Preset, Color Transformation Control and Saturation
- Static Defect Correction, Sharpness, Noise Reduction(Mono)
- Timer, Counter, LUTs and storable user sets
- Remove Parameter Limit to expand the range of Parameter
- Data storage area for saving algorithm coefficients and parameter configuration

Specifications

Model	MARS-900-120GTC	MARS-900-120GTM
Resolution	4192(H) × 2160(V)	
Sensor	Gpixel GMAX2509, Global shutter CMOS	
Sensor Format	2/3"	
Pixel Size	2.5μm × 2.5μm	
Frame Rate	120.36fps	
ADC	12bit	
Pixel Bit Depth	8bit, 12bit	
Mono/Color	Color	Mono
Pixel Formats	Bayer GB8 / Bayer GB12	Mono8 / Mono12
SNR	36.46dB	36.44dB
Exposure Time	4μs ~ 1s	
Gain	0dB ~ 16dB; Default: 0dB, Steps: 0.1dB	
Binning	1×1, 2×1 (No Vertical Binning)	
Decimation	Horizontal FPGA, Vertical Sensor: 1×1, 1×2, 2×1, 2×2	
Synchronization	Hardware trigger, software trigger	
Acquisition Control	Single frame, Continuous, Software trigger, Hardware trigger	
Reverse X/Y	Reverse X/Y	
I/O Interface	1 input and 1 output with opto-isolated, 1 bidirectional programmable GPIO	
Data Interface	10GigE	
Power Supply	12VDC-10% ~ 24VDC+10%	
Power Consumption	< 12.7W @ 24VDC	
Operating Temp.	0° C ~ +50° C	
Storage Temp.	-20° C ~ +70° C	
Operating Humidity	10% ~ 80%	
Lens Mount	C	
Dimensions	60mm × 60mm × 54mm (without lens adapter or connectors)	
Weight	340g	
OS	Win10 32bit, 64bit OS, 64bit OS is recommended	
Conformity	CE, RoHS, GigE Vision, GenICam	

I/O Interface



Pin	Definition	Core Color	Description
1	Line 0+	Green	Opto-isolated input +
2	GND	Blue	PWR GND & GPIO GND
3	Line 0-	Grey	Opto-isolated input -
4	POWER_IN	Purple	Camera external power 12V (-10%) ~ +24V (+10%)
5	Line 2	Orange	GPIO input/output
6	RS232 Rx	Pink	RS232 receive*
7	Line 1-	White Green	Opto-isolated output -
8	Line 1+	White Blue	Opto-isolated output +
9	GND	White Grey	PWR GND & GPIO GND
10	GND	White Purple	PWR GND & GPIO GND
11	POWER_IN	White Orange	Camera external power 12V (-10%) ~ +24V (+10%)
12	RS232 Tx	White Pink	RS232 transmit*

*Not currently supported

Technical Drawing

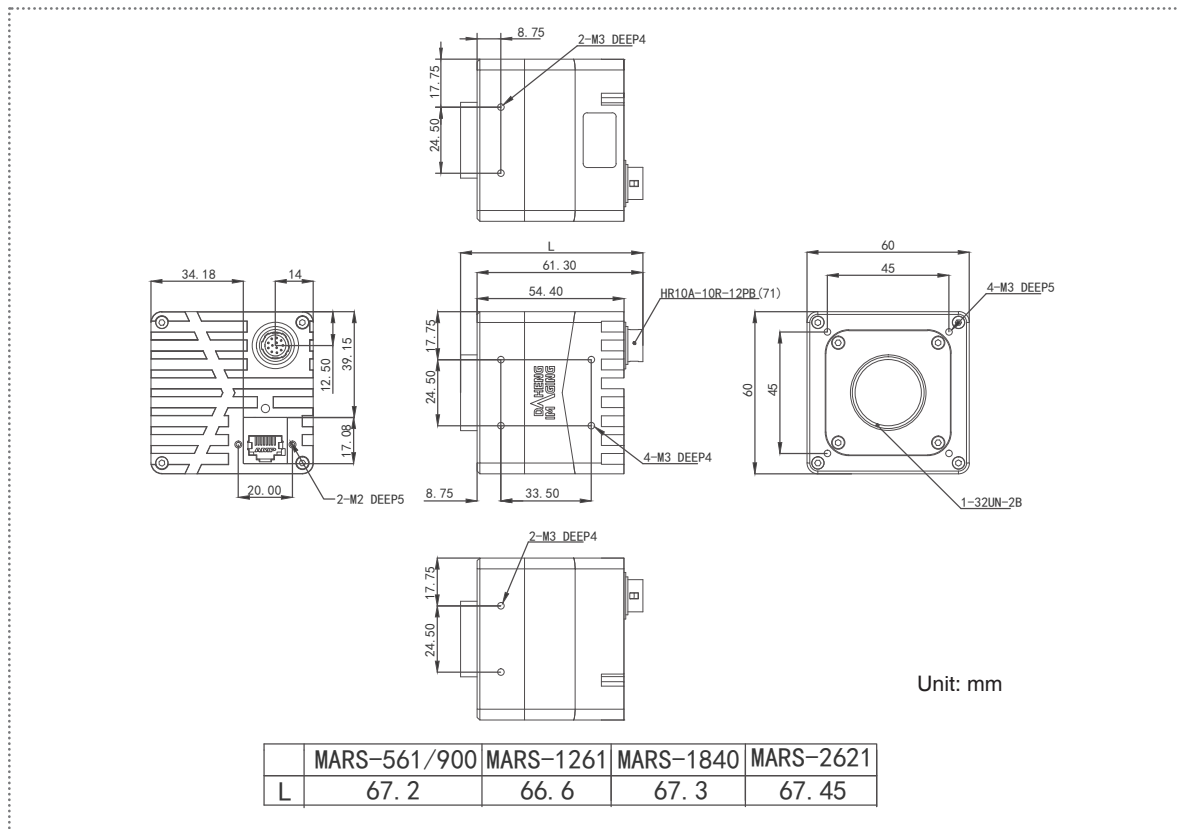

China Daheng Group, Inc. Beijing Image Vision Technology Branch

12F Daheng Science & Technology Tower, No.3 Suzhou Street, Haidian District, Beijing China, 100080

Tel: +86 10 82828878

E-mail: isales@daheng-imaging.com