

# MARS-6500-18GTM/C-NF

65MP CMOS 10GigE Area Scan Camera



The MARS-6500-18GTM/C-NF is a monochrome/color GigE Vision camera with the Gpixel GMAX3265 CMOS sensor. The MARS-6500-18GTM/C-NF is capable of 10Gbit/s maximum transfer data rate, and has opto-isolated I/Os. Thanks to locking screw connectors, the MARS cameras can secure the reliability of cameras deployed in harsh environments. The MARS cameras are industrial digital cameras with high reliability and high performance ratio.

## Applications

Suitable for 3C, lithium battery, photovoltaic, railway, AR and other industrial applications.

## Spectral Response

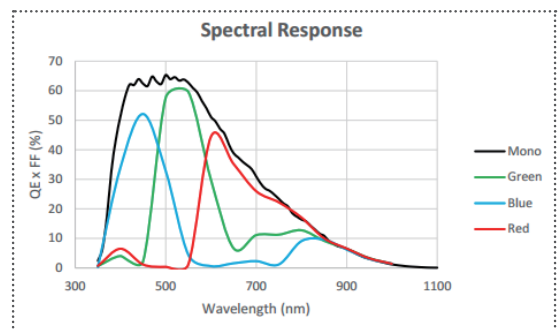

## Features

- Time Stamp, Binning, Decimation, Reverse X/Y
- The Sequencer Control supports multiple sets of parameters configuration of FFC
- Trigger mode: Frame Start /Frame Burst Start
- Gain, GainAuto, Gamma, Black Level, Digital Shift, Flat Field Correction
- Color models support Light Source Preset, Color Transformation Control and Saturation
- Static Defect Correction, Hot Pixel Correction, Sharpness, Noise Reduction(Mono)
- Timer, Counter, LUTs and storable user sets
- Remove Parameter Limit to expand the range of Parameter
- Data storage area for saving algorithm coefficients and parameter configuration
- Fan cooling

## Specifications

Model	MARS-6500-18GTC-NF	MARS-6500-18GTM-NF
Resolution	9344(H) × 7000(V)	
Sensor	Gpixel GMAX3265, Global shutter CMOS	
Sensor Format	2.3"	
Pixel Size	3.2μm × 3.2μm	
Frame Rate	17.73fps	
ADC	12bit	
Pixel Bit Depth	8bit, 12bit	
Mono/Color	Color	Mono
Pixel Formats	Bayer GB8 / Bayer GB12	Mono8 / Mono12
SNR	40.42dB	40.05dB
Exposure Time	14μs ~ 1s	
Gain	0dB ~ 16dB; Default: 0dB, Steps: 0.1dB	
Binning	1×1, 1×2, 2×1, 2×2	
Decimation	Horizontal FPGA, Vertical Sensor: 1×1, 1×2, 2×1, 2×2	
Synchronization	Hardware trigger, software trigger	
Acquisition Control	Single frame, Continuous, Software trigger, Hardware trigger	
Reverse X/Y	Reverse X/Y	
I/O Interface	1 input and 1 output with opto-isolated, 1 bidirectional programmable GPIO	
Data Interface	10GigE	
Power Supply	12VDC-10% ~ 24VDC+10%	
Power Consumption	< 16W @ 12VDC	
Operating Temp.	0° C ~ +50° C	
Storage Temp.	-20° C ~ +70° C	
Operating Humidity	10% ~ 80%	
Lens Mount	M58-D1(11.48mm), M58(19.5mm), F	
Dimensions	74mm × 74mm × 59mm (without lens adapter or fan)	
Weight	540g	
OS	Win10/Win11 32bit, 64bit OS, 64bit OS is recommended	
Conformity	CE, RoHS, GigE Vision, GenICam	



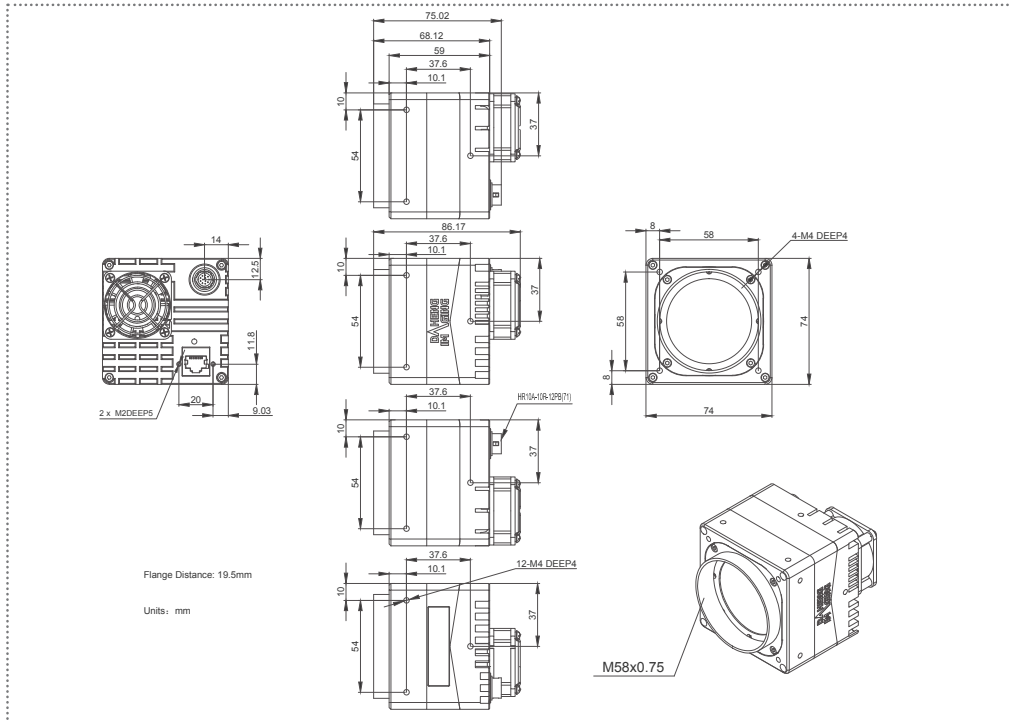

MARS-6500-18GTM/C-NF M58, M58-mount, flange distance:19.5mm

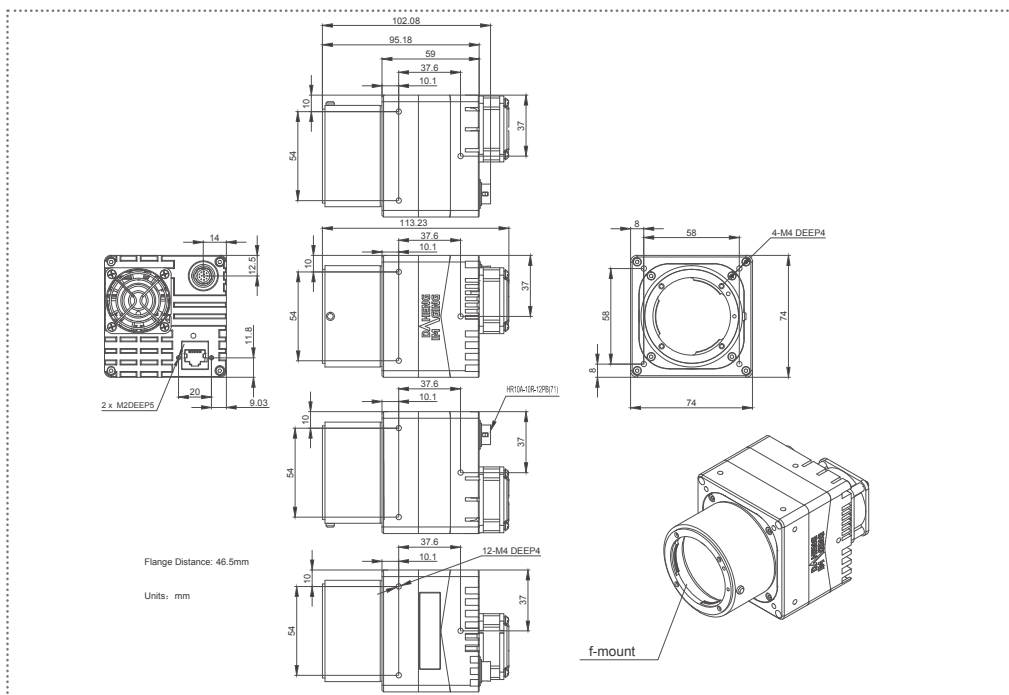

MARS-6500-18GTM/C-NF F, F-mount

China Daheng Group, Inc. Beijing Image Vision Technology Branch

12F Daheng Science & Technology Tower, No.3 Suzhou Street, Haidian District, Beijing China, 100080

Tel: +86 10 82828878

E-mail: isales@daheng-imaging.com