

2/3" F1.6/35MM/5MEGA/C-MOUNT

FOCAL LENGTH	f=35MM
F.NO	F=1:1.6~16
FOCUS DISTANCE	0.15M~1.5M
FLANGE BACK	17.526MM IN AIR
BACK FOCUS	12.52MM IN AIR
FILTER SCREW SIZE	M30.5*P0.5
MOUNT	C
REL.ILLUMINATION	≥76%
CHIEF RAY ANGLE	<5°

FIELD OF VIEW	SENSOR	2/3"	1/2"
	D	17.3°	12.5°
	H	13.7°	10°
	V	10.2°	7.3°

TV DISTORTION	<0.15%	<0.1%
---------------	--------	-------

WORKING DISTANCE	OPTICAL MAGNIFICATION	2/3" FIELD OF VIEW	
		H	V
MM	D		
900	0.038	232.7	147.53
800	0.043	207.87	155.9
750	0.045	195.45	146.59
700	0.048	183.03	137.27
650	0.052	170.61	127.96
600	0.056	158.19	118.64
550	0.061	145.77	109.33
500	0.066	133.35	100.01
450	0.073	120.92	90.963
400	0.082	108.5	81.375
350	0.092	96.072	72.054
300	0.106	83.641	62.731
250	0.124	71.206	53.404
200	0.151	58.762	44.071
150	0.191	46.304	34.728

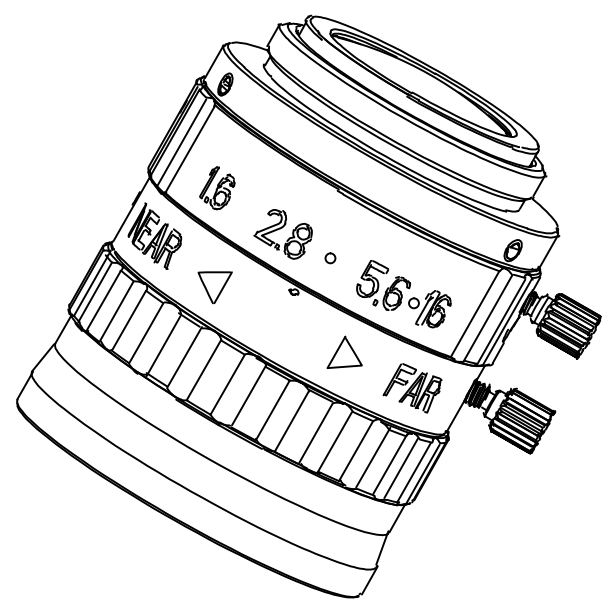
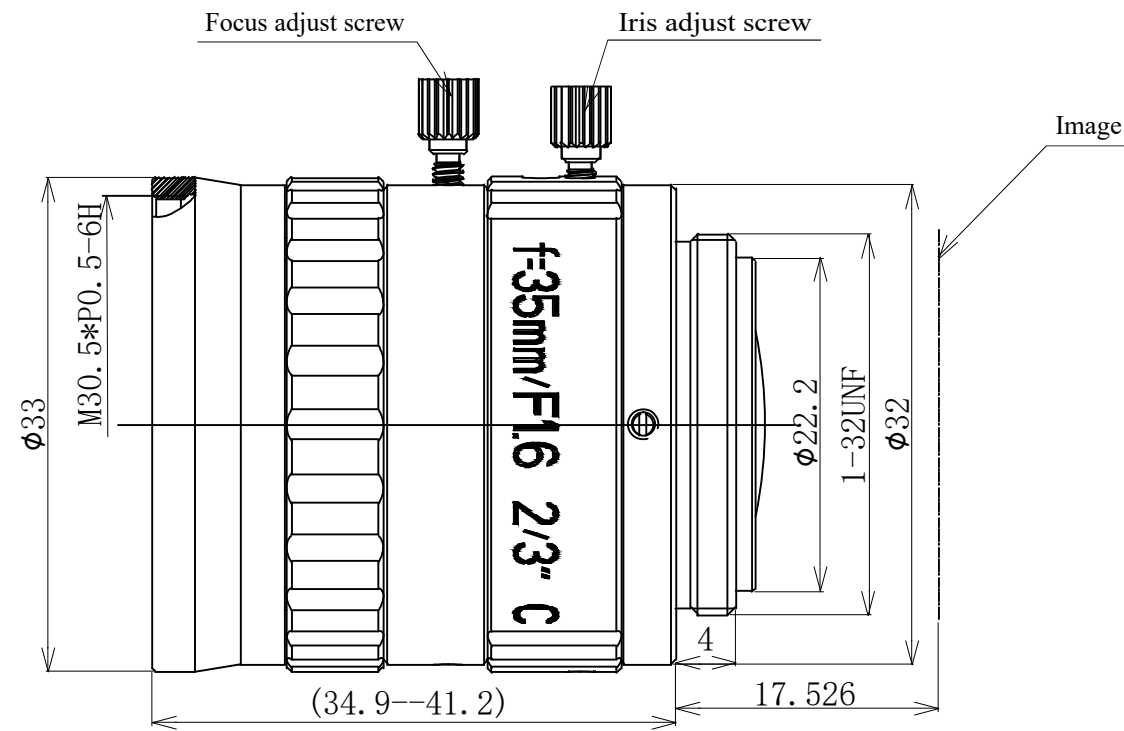

WORKING TEMPERATURE	-40°C~80°C
STORAGE TEMPERATURE	-40°C~85°C

Common Tolerance		④					
Angle		±0.5°	③				
0.000		±0.01	②				
0.00		±0.03	①				
Rev	Description	Name	Date				
	Design	Examine	Checked	Approved			
0.0	±0.05						
0	±0.1						

Model	
3RD ANGLE PROJ	
Unit	mm
Scale	2:1
Ver	00
Date	2018.03.01

SBS-3516-5MP

vision solution