

1.1" F2.4/50MM/20MEGA/C-MOUNT

FOCAL LENGTH	f=50MM			
F.NO	F=1:2.4~16			
FOCUS DISTANCE	0.1M~∞			
FLANGE BACK	17.526MM IN AIR			
BACK FOCUS	30			
FILTER SCREW SIZE	M40.5*P0.5			
MOUNT	C			
REL.ILLUMINATION	≥70%			
Front/Rear Effective Dia	Front Φ26 Rear Φ18			
FIELD OF VIEW	SENSOR	1.1"	1"	2/3"
	D	19.3°	17.6°	12.1°
	H	15.5°	14.1°	9.7°
	V	11.6°	10.5°	7.2°
TV DISTORTION	<0.1%	<0.08%	<0.05%	

WORKING DISTANCE	OPTICAL MAGNIFICATION	1.1" FIELD OF VIEW	
		H	V
MM	D		
2000	0.023X	612.992	459.691
1800	0.026X	550.524	412.893
1500	0.031X	456.940	342.076
1000	0.047X	301.024	225.768
900	0.052X	269.859	202.394
800	0.059X	238.704	179.028
700	0.068X	207.566	155.674
600	0.08X	176.449	132.336
550	0.088X	160.902	120.677
500	0.097X	145.367	109.025
450	0.109X	129.845	97.384
400	0.123X	114.34	85.755
350	0.143X	98.86	74.145
300	0.169X	83.42	62.565
200	0.263X	53.502	40.126

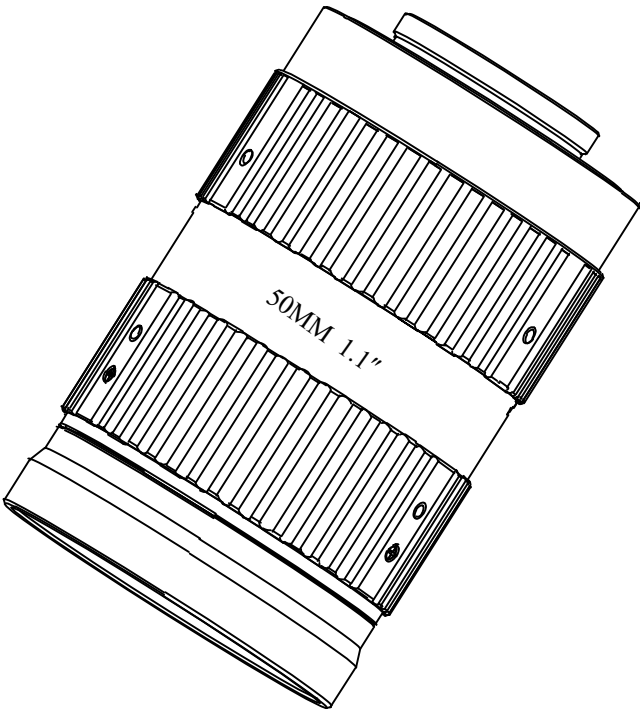
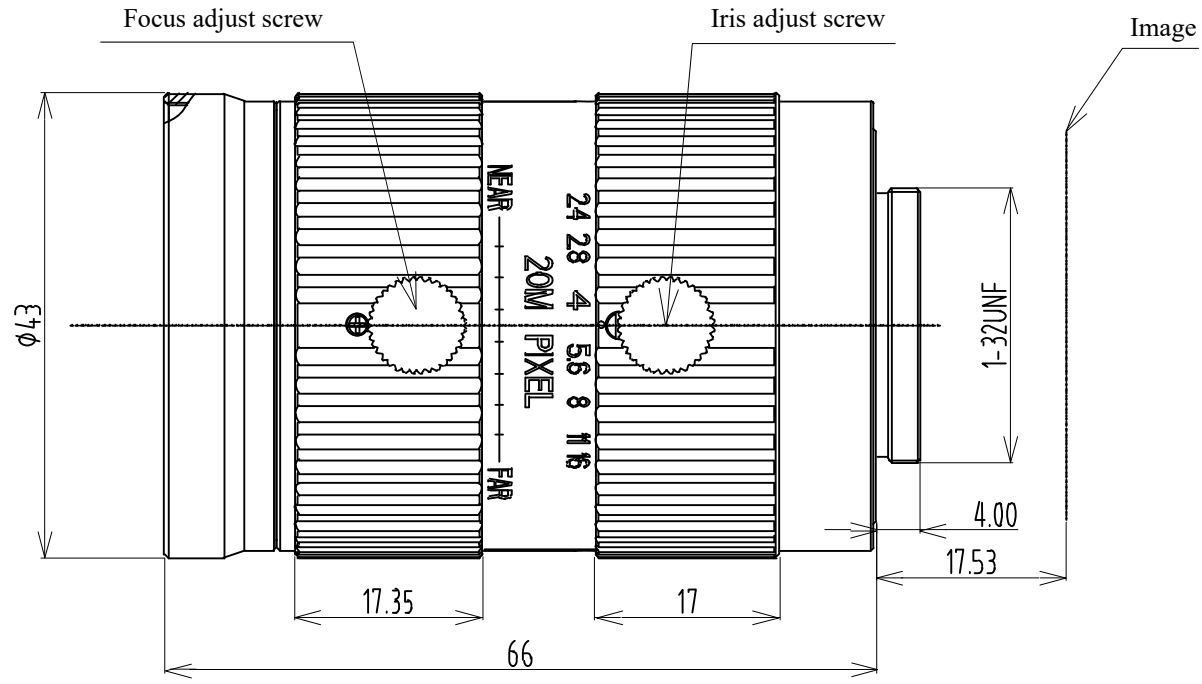

WORKING TEMPERATURE -40°C~80°C
 STORAGE TEMPERATURE -40°C~85°C

Common Tolerance		④				
Angle	±0.5°	③				
0.000	±0.01	②				
0.00	±0.03	①				
0.0	±0.05	Rev	Description	Name	Date	
0	±0.1		Design	Examine	Checked	Approved

Model	
3RD ANGLE PROJ	
Unit	mm
Scale	2:1
Ver	00
Date	2018.09.18

SBS-5024-20MP



vision solution